

Before returning this product call

1-800-4-DEWALT

IF YOU SHOULD EXPERIENCE A PROBLEM WITH YOUR DEWALT PURCHASE,

CALL 1-800-4-DEWALT

IN MOST CASES, A DEWALT REPRESENTATIVE CAN RESOLVE
YOUR PROBLEM OVER THE PHONE.

IF YOU HAVE A SUGGESTION OR COMMENT, GIVE US A CALL.
YOUR FEEDBACK IS VITAL TO THE SUCCESS OF DEWALT'S QUALITY
IMPROVEMENT PROGRAM.

Questions? Visit us at www.dewalt.com

**INSTRUCTION MANUAL
GUIDE D'UTILISATION
MANUAL DE INSTRUCCIONES**

INSTRUCTIVO DE OPERACIÓN, CENTROS DE SERVICIO Y PÓLIZA DE
GARANTÍA. **ADVERTENCIA:** LÉASE ESTE INSTRUCTIVO ANTES DE
USAR EL PRODUCTO.

DEWALT®

**DW715
12" (305 mm) Compound Miter Saw
Scie à onglets mixtes, 305 mm (12 po)
Sierra ingletadora de 305 mm (12")**

FIG. 1

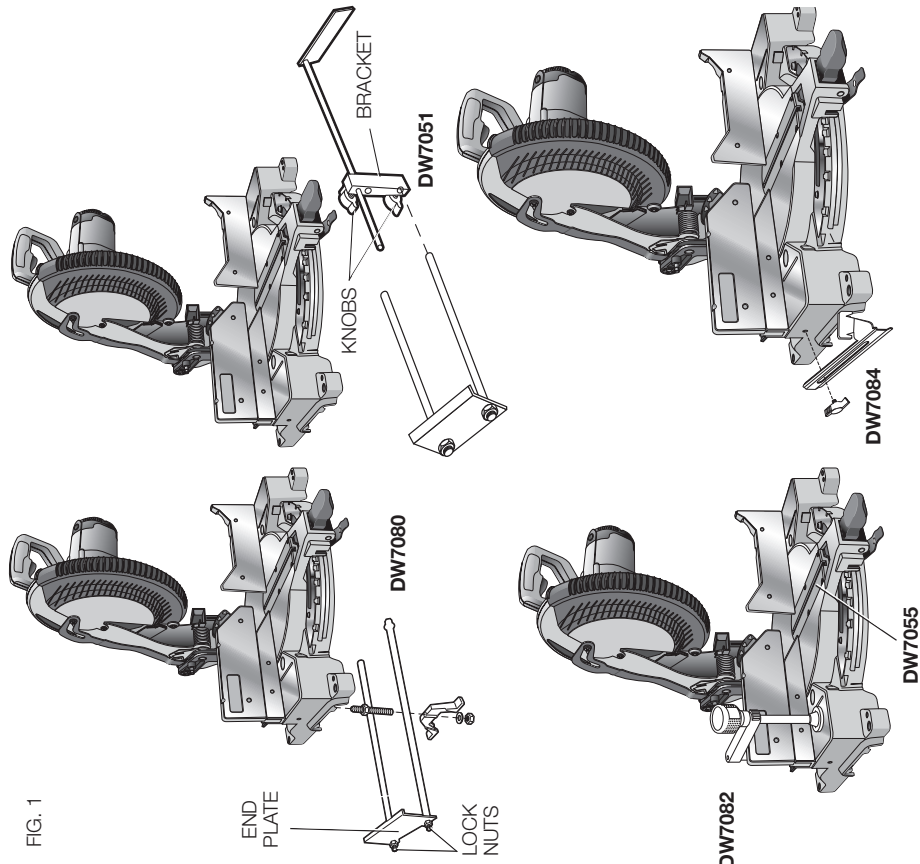

SAW BLADES: ALWAYS USE 12" (305 mm) SAW BLADES WITH 1" (25.4 mm) ARBOR HOLES. SPEED RATING MUST BE AT LEAST 4800 RPM. Never use a smaller diameter blade. It will not be guarded properly. Use crosscut blades only! Do not use blades designed for ripping, combination blades or blades with hook angles in excess of 7°.

BLADE DESCRIPTIONS		
APPLICATION	DIAMETER	TEETH
Construction Saw Blades (<i>thin kerf with anti-stick rim</i>)		
General Purpose	12" (305 mm)	40
Fine Crosscuts	12" (305 mm)	60
Woodworking Saw Blades (<i>provide smooth, clean cuts</i>)		
Fine crosscuts	12" (305 mm)	80
Non-ferrous metals	12" (305 mm)	96

NOTE: For cutting non-ferrous metals, use only saw blades with TCG teeth designed for this purpose.

Unpacking Your Saw

Check the contents of your miter saw carton to make sure that you have received all parts. In addition to this instruction manual, the carton should contain:

- One No. DW715 miter saw.
- One DEWALT 12" (305 mm) dia. saw blade
- One blade wrench in wrench pocket shown in Figure 2.
- One DW7053 dustbag (some models).

Specifications

CAPACITY OF CUT

50° miter left and right
48° bevel left, 3° bevel right

0° miter

Max. Height 3.5" (89 mm)
Max. Width 7.7" (196 mm)

45° miter

Max. Height 3.5" (89 mm)
Max. Width 5.5" (140 mm)

45° bevel - Left

Max. Height 2.3" (58 mm)
Max. Width 7.7" (196 mm)

Result Width 6.5" (165 mm)
Result Height 2.6" (66 mm)

Result Width 4.7" (120 mm)
Result Height 2.6" (66 mm)

Result Width 6.7" (170 mm)
Result Height 1.7" (43 mm)

DRIVE

120 Volt Motor

- 1600 Watts (max in)
- 4000 RPM
- Roller Bearings
- Automatic Electric Brake

15 Amp Motor

Cut Helical Gears

Carbide Blade

DW7082

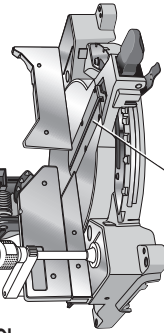

DW7084

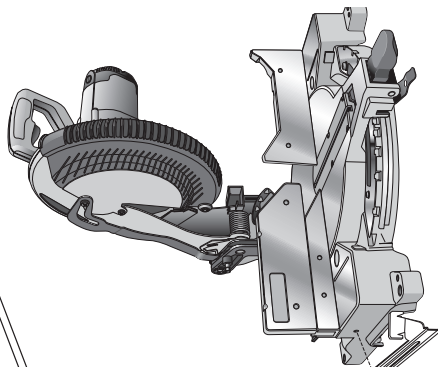

Automatic Electric Brake

Familiarization

Your miter saw is fully assembled in the carton. Open the box and lift the saw out by the convenient carrying handle, as shown in Figure 1A. Place the saw on a smooth, flat surface such as a workbench or a strong table.

Examine Figure 2 to become familiar with the saw and its various parts. The section on adjustments will refer to these terms and you must know what and where the parts are.

!CAUTION: Pinch Hazard. To reduce the risk of injury, keep thumb underneath the handle when pulling the handle down. The lower guard will move up as the handle is pulled down which could cause pinching. The handle is placed close to the guard for special cuts.

Press down lightly on the operating handle and pull out the lock down pin, as shown in Figure 2. Gently release the downward pressure and hold the arm allowing it to rise to its full height. Use the lock down pin when carrying the saw from one place to another. Always use the carrying handle to transport the saw or the hand indentations shown in Figure 2 and 4.

Bench Mounting

Holes are provided in all four feet to facilitate bench mounting, as shown in Figure 2. (Two different sized holes are provided to accommodate different sizes of screws. Use either hole, it is not necessary to use both.) Always mount your saw firmly to a stable surface to prevent movement. To enhance the tool's portability, it can be mounted to a piece of 1/2" (12.7 mm)

FIG. 1A

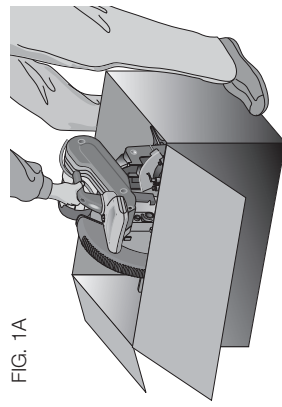

or thicker plywood which can then be clamped to your work support or moved to other job sites and reclamped.

NOTE: If you elect to mount your saw to a piece of plywood, make sure that the mounting screws don't protrude from the bottom of the wood. The plywood must sit flush on the work support. When clamping the saw to any work surface, clamp only on the clamping bosses where the mounting screw holes are located. Clamping at any other point will surely interfere with the proper operation of the saw.

CAUTION: To prevent binding and inaccuracy, be sure the mounting surface is not warped or otherwise uneven. If the saw rocks on the surface place a thin piece of material under one saw foot until the saw sits firmly on the mounting surface.

IMPORTANT SAFETY INSTRUCTIONS

FIG. 2

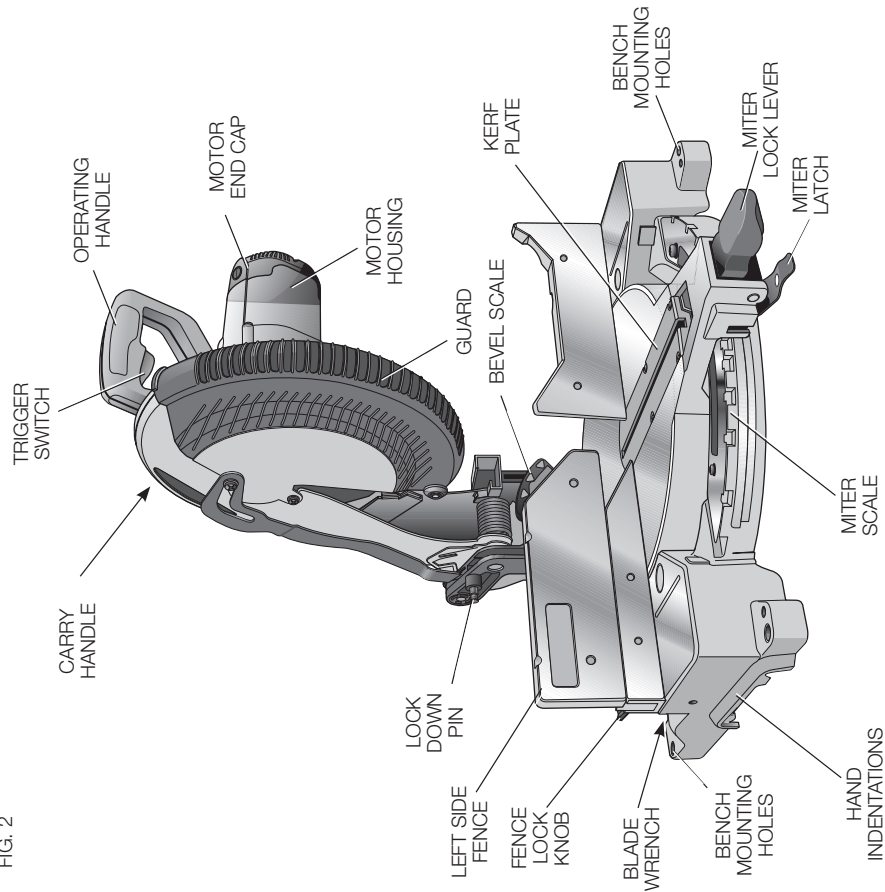

Changing or Installing a New Saw Blade (Fig. 3)

WARNING: To reduce the risk of serious personal injury, turn off the tool and disconnect it from the power source before attempting to move it, change accessories or make any adjustments.

CAUTION:

- Never depress the spindle lock button while the blade is under power or coasting.
- Do not cut ferrous metal (containing iron or steel) or masonry or fiber cement product with this miter saw.

Removing the Blade (Fig. 3, 3A)

1. Unplug the saw.
2. Raise the arm to the upper position and raise the lower guard (A) as far as possible.

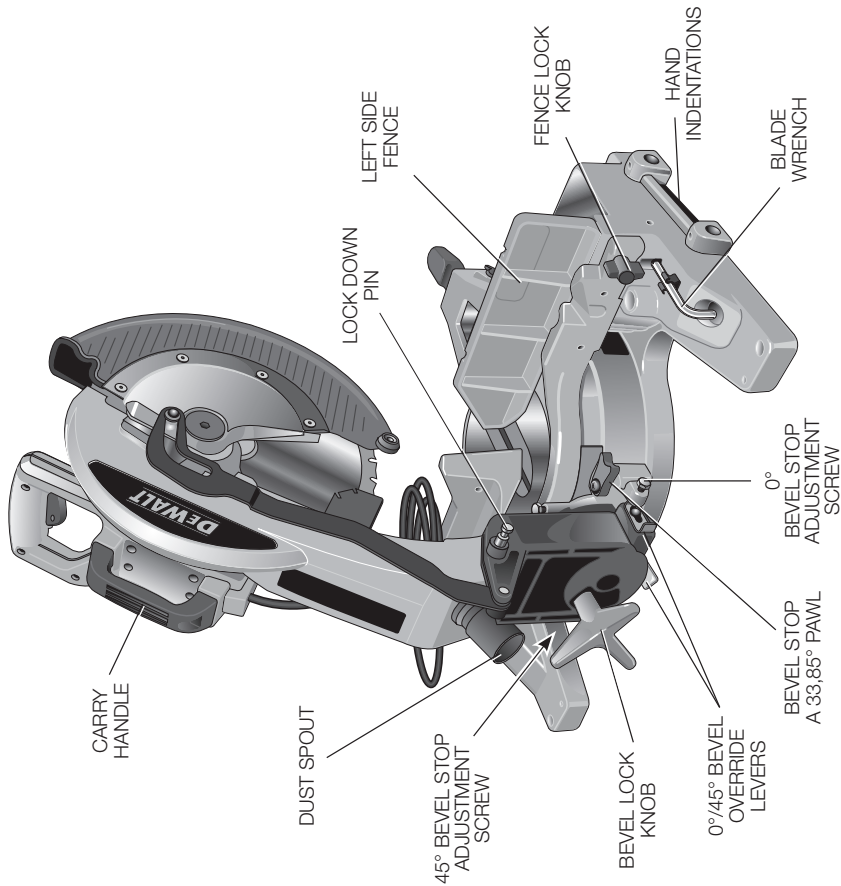

- Loosen, but do not remove guard bracket screw (B) until the bracket can be raised far enough to access the blade screw. Lower guard will remain raised due to the position of the guard bracket screw.

FIG. 3

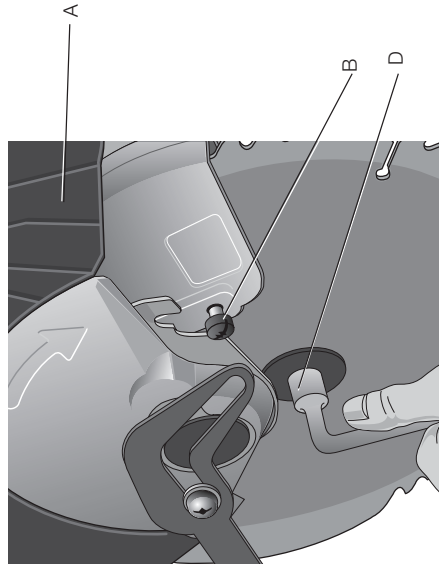

- Depress the spindle lock button (C) while carefully rotating the saw blade by hand until the lock engages.
- Keeping the button depressed, use the other hand and the wrench provided (D) to loosen the blade screw. (Turn clockwise, left-hand threads.)

- Remove the blade screw (E), outer blade clamp (F), and blade (G). The inner blade clamp (I), and if used, the 1" (25.4 mm) blade adapter (H), may be left on the spindle.

NOTE: For blades with a blade hole of 5/8" (15.88 mm), the 1" (25.4 mm) blade adapter is not used.

Installing a Blade

- Unplug the saw.
- With the arm raised, the lower guard held open and the guard bracket, place the blade on the spindle, onto the blade adapter [if using a blade with a 1" (25.4 mm) diameter blade hole] and against the inner blade clamp with the teeth at the bottom of the blade pointing toward the back of the saw.
- Assemble the outer blade clamp onto the spindle.
- Install the blade screw (E) and, engaging the spindle lock, tighten the screw firmly with wrench provided. (Turn counterclockwise, left-hand threads.)

NOTE: When using blades with a 5/8" (15.88 mm) diameter blade hole, the blade adapter will not be used and should be stored in a safe place for future use.

- Return the guard bracket to its original position and firmly tighten the guard bracket screw (B) to hold bracket in place.

⚠WARNING:

- The guard bracket must be returned to its original position and the screw tightened before activating the saw.
- Failure to do so may allow the guard to contact the spinning saw blade resulting in damage to the saw and severe personal injury.

FIG. 3A

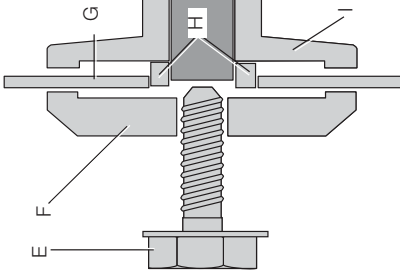
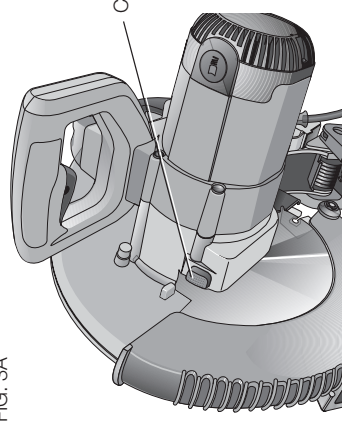

Transporting the Saw (Fig. 2, 4)

⚠WARNING: To reduce the risk of serious personal injury, turn off the tool and disconnect it from the power source before attempting to move it, change accessories or make any adjustments.

⚠WARNING: To reduce the risk of serious personal injury, ALWAYS lock the miter lock handle, bevel lock handle, down lock pin and fence adjustment knob before transporting saw.

In order to conveniently carry the miter saw from place to place, a carrying handle has been included on the top of the saw arm and hand indentations in the base, as shown in Figures 2 and 4.

FIG. 4

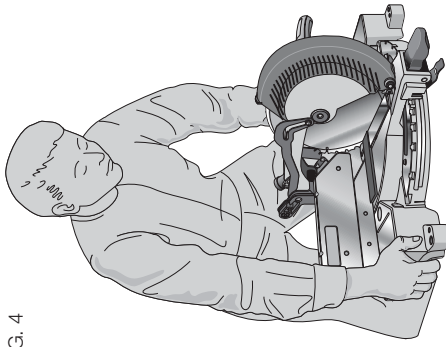

ADJUSTMENTS

⚠WARNING: To reduce the risk of serious personal injury, turn off the tool and disconnect it from the power source before attempting to move it, change accessories or make any adjustments.

NOTE: Your miter saw is fully and accurately adjusted at the factory at the time of manufacture. If readjustment due to shipping and handling or any other reason is required, follow the steps below to adjust your saw.

Once made, these adjustments should remain accurate. Take a little time now to follow these directions carefully to maintain the accuracy of which your saw is capable.

MITER SCALE ADJUSTMENT (FIG. 5)

Place a square against the saw's fence and blade. (Do not touch the tips of the blade teeth with the square. To do so will cause an inaccurate measurement.) Unlock miter lock lever (J) and swing the miter arm until the miter latch locks it at the 0 miter position. Do not lock miter lock lever (J). If the saw blade is not exactly perpendicular to the fence, loosen the three screws that hold the miter scale to the base and move the scale left or right until the blade is perpendicular to the fence, as measured with the square. Retighten the three screws. Pay no attention to the reading of the miter pointer at this time.

FIG. 5

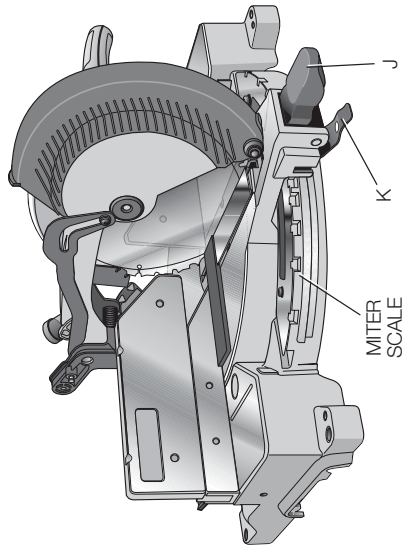

MITER POINTER ADJUSTMENT (FIG. 5, 6)

To unlock, lift the miter lock lever (J) up and squeeze the miter latch (K) to move the miter arm to the zero position. With the miter lock lever unlocked allow the miter latch to snap into place as you rotate the miter arm to zero. Observe the pointer and miter scale through the viewing opening shown in Figure 6. If the pointer does not indicate exactly zero, loosen the screw holding the pointer in place, reposition the pointer and tighten the screw.

FIG. 6

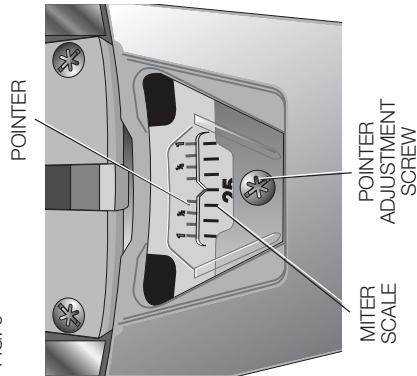

BEVEL SQUARE TO TABLE (FIG. 2, 7, 8)

To align the blade square to the rotary table, lock the arm in the down position. Place a square against the blade taking care to not have the square on top of a tooth. Loosen the bevel lock knob (L) and ensure the arm is firmly against the 0° bevel stop. Move the 0° bevel stop adjusting screw (O) as necessary so that the blade is at 0° bevel to the table. Ensure the bevel override levers (N) are pushed inward to obtain an accurate adjustment.

FIG. 7

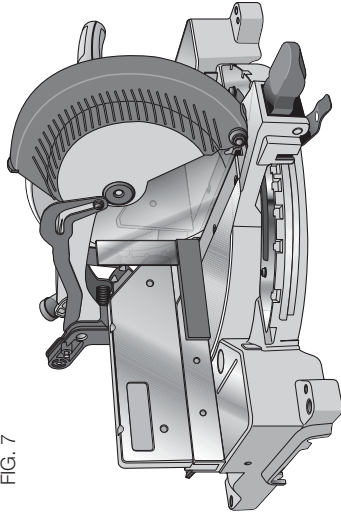

BEVEL POINTER (FIG. 8)

If the bevel pointer (M) does not indicate zero, loosen the screw that holds it in place and move the pointer as necessary. Do not remove the steel plate in front of the bevel pointer. This plate prevents wood resin from accumulating on the bevel scale during use.

ADJUSTING THE BEVEL STOP TO 45° LEFT (FIG. 8)

NOTE: Adjust the 45° bevel angle only after performing the 0° bevel angle and pointer adjustment. Ensure the 45° bevel override levers (N) are pushed inward to obtain an accurate adjustment.

To adjust the left 45° bevel stop, first loosen the bevel lock knob (L) and tilt the head to the left. If the pointer does not indicate exactly 45°, turn the left bevel stop screw until the pointer reads 45°.

ADJUSTING THE BEVEL STOP TO 33.85° (FIG. 8)

NOTE: Adjust the 33.85° bevel angle only after performing the 0° bevel angle and pointer adjustment.

To set the 33.85° bevel angle, flip out the stop pawl (P). Loosen the bevel lock knob (L) and tilt the head to the left. If the pointer does not indicate exactly 33.85°, turn the screw contacting the pawl until the pointer reads 33.85°.

FENCE ADJUSTMENT (FIG. 8)

⚠WARNING: To reduce the risk of serious personal injury, turn off the tool and disconnect it from the power source before attempting to move it, change accessories or make any adjustments.

In order that the saw can bevel to a full 48° left, the fences can be adjusted to provide clearance. To adjust a fence, loosen the plastic knob (R), and slide the fence outward. Make a dry run with the saw turned off and check for clearance. Adjust the fence to be as close to the blade as practical to provide maximum workpiece support, without interfering with arm up and down movement. Tighten knob securely. When the bevel operations are complete, don't forget to relocate the fence.

NOTE: The guide groove of the fences can become clogged with sawdust. If the guide groove becomes clogged, use a stick, low pressure air or a vacuum to clear.

FIG. 8

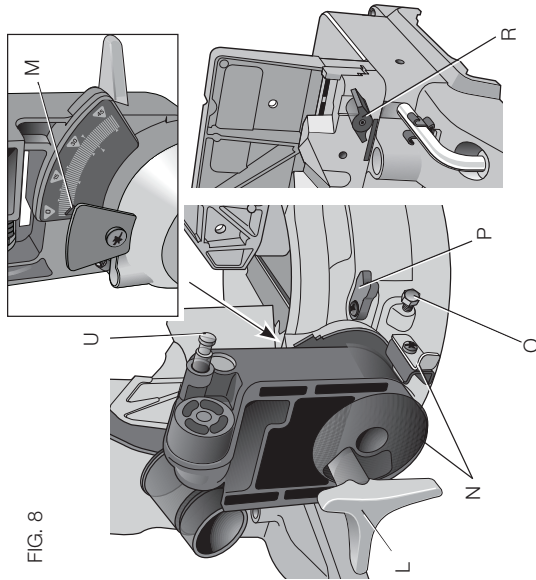

AUTOMATIC ELECTRIC BRAKE (FIG. 2)

Your saw is equipped with an automatic electric blade brake which stops the saw blade within 5 seconds of trigger release. This is not adjustable.

On occasion, there may be a delay after trigger release to brake engagement. On rare occasions, the brake may not engage at all and the blade will coast to a stop.

If a delay or "skipping" occurs, turn the saw on and off 4 or 5 times. If the condition persists, have the tool serviced by an authorized DEWALT service center.

Always be sure the blade has stopped before removing it from the kerf plate. The brake is not a substitute for guards or for ensuring your own safety by giving the saw your complete attention.

GUARD ACTUATION AND VISIBILITY

⚠CAUTION: Pinch Hazard. To reduce the risk of injury, keep thumb underneath the handle when pulling the handle down. The lower guard will move up as the handle is pulled down which could cause pinching.

The blade guard on your saw has been designed to automatically raise when the arm is brought down and to lower over the blade when the arm is raised.

The guard can be raised by hand when installing or removing saw blades or for inspection of the saw. NEVER RAISE THE BLADE GUARD MANUALLY UNLESS THE SAW IS TURNED OFF.

NOTE: Certain special cuts of large material will require that you manually raise the guard. The front section of the guard is lowered for visibility while cutting. Although the louvers dramatically reduce flying debris, there are openings in the guard and safety glasses should be worn at all times when viewing through the louvers. Refer to **Cutting Large Material** under **Special Cuts**.

MITER LOCK ADJUSTMENT (FIG. 10)

The miter lock rod should be adjusted if the table of the saw can be moved when the miter lock handle is locked down. To adjust, put the miter lock handle in the up position. Using a slotted screwdriver, adjust the lock rod in 1/8 clockwise turn increments to increase the lock force. To ensure the miter lock is functioning properly, re-lock miter lock handle to a non-detent miter angle.

FIG. 9

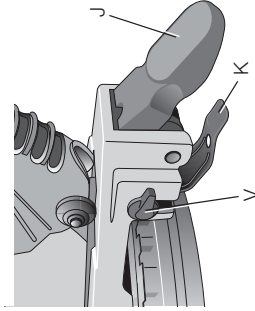
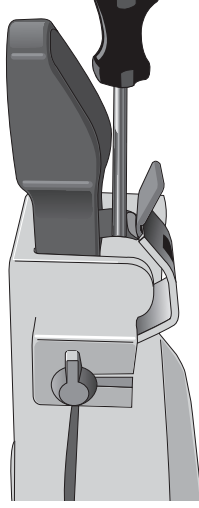

FIG. 10



Brushes (Fig. 2)

⚠WARNING: To reduce the risk of serious personal injury, turn off the tool and disconnect it from the power source before attempting to move it, change accessories or make any adjustments.

Inspect carbon brushes regularly by unplugging the tool, removing the motor end cap (Fig. 2) and removing the brush cap that holds the spring-loaded brush assembly. Keep brushes clean and sliding freely in their guides. Always replace a used brush in the same orientation in the holder as it was prior to its removal. If the brush is worn down to approximately 1/2" (12.7 mm), the spring will no longer exert pressure and they must be replaced. Use only identical DEWALT brushes. Use of the correct grade of brush is essential for proper operation of electric brake. New brush assemblies are available at DEWALT service centers. The tool should be allowed to "run in" (run at no load) for 10 minutes before use to seat new brushes. The electric brake may be erratic in operation until the brushes are properly seated (worn in). Always replace the brush inspection cap after inspection or servicing the brushes. While "running in" DO NOT TIE, TAPE, OR OTHERWISE LOCK THE TRIGGER SWITCH ON. HOLD BY HAND ONLY.

Controls

Your compound miter saw has several main controls, which will be discussed briefly here. For more information on these controls, see the respective sections later in the manual.

MITER CONTROL (FIG. 5, 9)

The miter lock lever (J) and miter latch (K) allows you to miter your saw 50° left and right. To miter the saw, unlock miter lock lever (J) by pulling upward, squeeze the miter latch (K) and set the miter angle desired on the miter scale. Lock miter lock handle by pressing downward. Override the miter latch by rotating knob (V, Fig. 9).

TRIGGER SWITCH (FIG. 2)

The trigger switch turns your saw on and off. A hole is provided in the trigger for insertion of a padlock to secure the saw.

BEVEL LOCK (FIG. 8)

The bevel lock knob (L) allows you to bevel the saw 48° left. To loosen the handle and adjust the bevel setting, turn the handle counterclockwise, the saw head bevels easily to the left. To tighten, turn the handle clockwise. Bevel degree markings are on the bottom front of the saw arm (M, Fig. 8).

0°/45° BEVEL STOP OVERRIDES (FIG. 8)

The bevel stop overrides (N) are held secure with their attachment screw to prevent inadvertent movement. Use the bit on the blade wrench to loosen the attachment screw. This allows the slides, to be pulled outward and the saw head to pivot past the 0°/45° mark. Be sure to retighten the attachment screw when finished.

33.85° BEVEL STOPS (FIG. 8)

The pawl (P) is used to stop the saw head bevel setting at 33.85°. This setting is used primarily for cutting crown moldings laid flat on the table.

HEAD DOWNLOCK PIN (FIG. 8)

To lock the saw head in the down position, push the head down, push the pin (U) in and release the saw head. This will hold the saw head safely down for moving the saw from place to place. To release, press the saw head down and pull the pin out.

OPERATION

⚠WARNING: To reduce the risk of serious personal injury, turn off the tool and disconnect it from the power source before attempting to move it, change accessories or make any adjustments.

⚠WARNING: Always use eye protection. All users and bystanders must wear eye protection that conforms to ANSI Z87.1 (CAN/CSA Z94.3).

Plug the saw into any household 60 Hz power source. Refer to the nameplate for voltage. Be sure the cord will not interfere with your work.

SWITCH

To turn the saw on, depress the trigger switch. To turn the tool off, release the switch. Allow the blade to spin up to full operating rpm before making the cut. Release the trigger switch and allow the brake to stop the blade before raising the saw head. There is no provision for locking the switch on, but a hole is provided in the trigger for insertion of a padlock to lock the saw off.

CUTTING WITH YOUR SAW

NOTE: Although this saw will cut wood and many non-ferrous materials, we will limit our discussion to the cutting of wood only. The same guidelines apply to the other materials. **DO NOT CUT FERROUS (IRON AND STEEL) MATERIALS OR MASONRY WITH THIS SAW.** Do not use any abrasive blades.

CROSSCUTS

Cutting of multiple pieces is not recommended but can be done safely by ensuring that each piece is held firmly against the table and fence. A crosscut is made by cutting wood across the grain at any angle. A straight crosscut is made with the miter arm at the zero degree position. Set the miter arm at zero, hold the wood on the table and firmly against the fence. Turn on the saw by squeezing the trigger.

FIG. 11

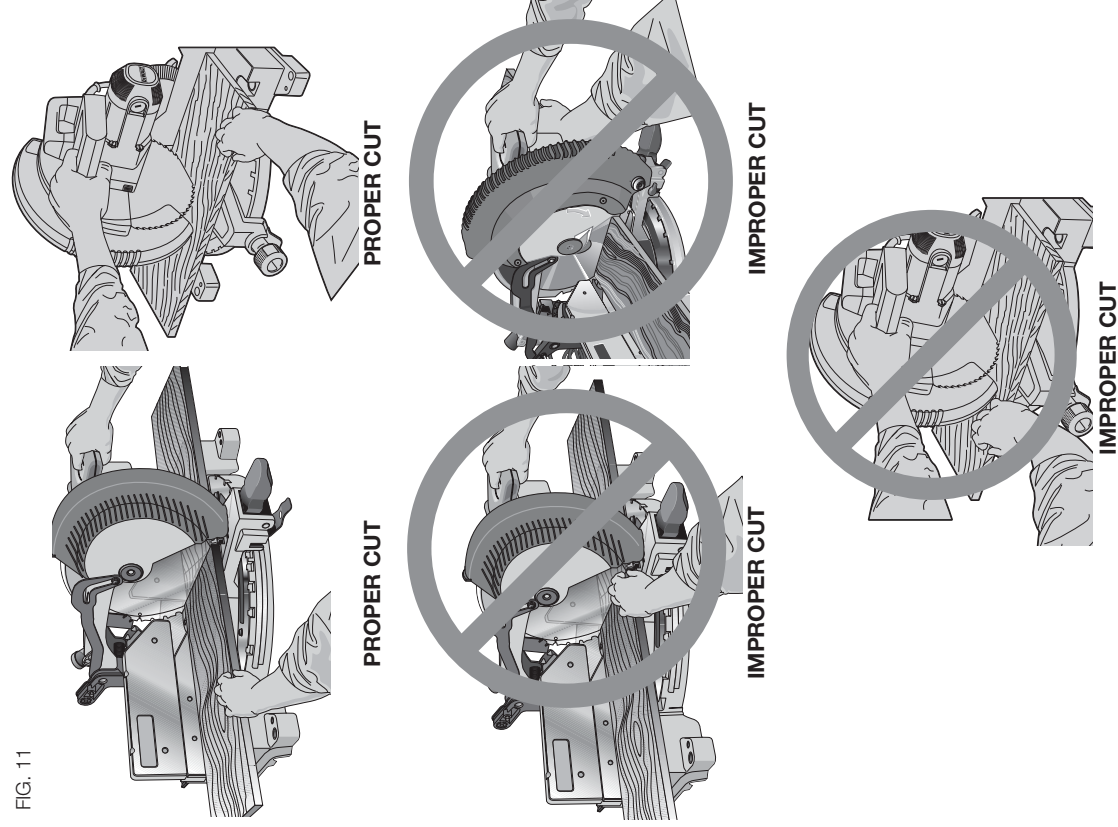

⚠ CAUTION: Always use a work clamp to maintain control and reduce the risk of workpiece damage and personal injury.

When the saw comes up to speed (about 1 second) lower the arm smoothly and slowly to cut through the wood. Let the blade come to a full stop before raising arm.

Miter crosscuts are made with the miter arm at some angle other than zero. This angle is often 45° for making corners, but can be set anywhere from zero to 50° left or right. After selecting the desired miter angle, be sure to lock miter lock lever. Make the cut as described above.

To cut through an existing pencil line on a piece of wood, match the angle as close as possible. Cut the wood a little too long and measure from the pencil line to the cut edge to determine which direction to adjust the miter angle and recut. This will take some practice, but it is a commonly used technique.

BEVEL CUTS (FIG. 8, 19)

A bevel cut is a crosscut made with the saw blade at a bevel to the wood. In order to set the bevel, loosen the bevel clamp knob (L) and move the saw to the left as desired. (It is necessary to move the fence to allow clearance). Once the desired bevel angle has been set, tighten the bevel clamp knob firmly.

Bevel angles can be set up to 48° left and can be cut with the miter arm set between zero and 50° right or left. At some extreme angles, the left side fence might have to be removed. To remove the left fence, unscrew the fence locking knob (R) several turns and slide the fence out.

QUALITY OF CUT

The smoothness of any cut depends on a number of variables. Things like material being cut, blade type, blade sharpness and rate of cut all contribute to the quality of the cut.

When smoothest cuts are desired for molding and other precision work, a sharp (60 tooth carbide) blade and a slower, even cutting rate will produce the desired results.

Ensure that material does not creep while cutting, clamp it securely in place. Always let the blade come to a full stop before raising arm.

If small fibers of wood still split out at the rear of the workpiece, stick a piece of masking tape on the wood where the cut will be made. Saw through the tape and carefully remove tape when finished.

For varied cutting applications, refer to the list of recommended saw blades for your saw and select the one that best fits your needs. Refer to **Saw Blades** under **Accessories**.

BODY AND HAND POSITION (FIG. 11)

Proper positioning of your body and hands when operating the miter saw will make cutting easier, more accurate and safer. Never place hands near cutting area. Place hands no closer than 6" (152 mm) from the blade. Hold the workpiece tightly to the table and the fence when cutting. Keep hands in position until the trigger has been released and the blade has completely stopped. ALWAYS MAKE DRY RUNS (UNPOWERED) BEFORE FINISH CUTS SO THAT YOU CAN CHECK THE PATH OF THE BLADE. DO NOT CROSS ARMS, AS SHOWN IN FIGURE 11.

Keep both feet firmly on the floor and maintain proper balance. As you move the miter arm left and right, follow it and stand slightly to the side of the saw blade. Sight through the guard louvers when following a pencil line.

CLAMPING THE WORKPIECE

⚠WARNING: To reduce the risk of serious personal injury, turn off the tool and disconnect it from the power source before attempting to move it, change accessories or make any adjustments.

⚠WARNING: A workpiece that is clamped, balanced and secure before a cut may become unbalanced after a cut is completed. An unbalanced load may tip the saw or anything the saw is attached to, such as a table or workbench. When making a cut that may become unbalanced, properly support the workpiece and ensure the saw is firmly bolted to a stable surface. Personal injury may occur.

⚠WARNING: The clamp foot must remain clamped above the base of the saw whenever the clamp is used. Always clamp the workpiece to the base of the saw—not to any other part of the work area. Ensure the clamp foot is not clamped on the edge of the base of the saw.

⚠CAUTION: Always use a work clamp to maintain control and reduce the risk of workpiece damage and personal injury.

If you cannot secure the workpiece on the table and against the fence by hand, (irregular shape, etc.) or your hand would be less than 6" (152 mm) from the blade, a clamp or other fixture must be used.

For best results use the DW7082 clamp made for use with your saw. It is available for purchase at your local retailer or DEWALT service center (Fig. 1).

Other aids such as spring clamps, bar clamps or C-clamps may be appropriate for certain sizes and shapes of material. Use care in selecting and placing these clamps. Take time to make a dry run before making the cut. The left fence will slide from side to side to aid in clamping.

TO INSTALL CLAMP (SOLD SEPARATELY (FIG. 1))

1. Insert the clamp into the hole behind the fence. The clamp should be facing toward the back of the miter saw. The groove on the clamp rod should be fully inserted into the base. Ensure this groove is fully inserted into the base of the miter saw. If the groove is visible, the clamp will not be secure.
2. Rotate the clamp 180° toward the front of the miter saw.
3. Loosen the knob to adjust the clamp up or down, then use the fine adjust knob to firmly clamp the workpiece.

NOTE: Place the clamp on the opposite side of the base when beveling. ALWAYS MAKE DRY RUNS (UNPOWERED) BEFORE FINISH CUTS TO CHECK THE PATH OF THE BLADE. ENSURE THE CLAMP DOES NOT INTERFERE WITH THE ACTION OF THE SAW OR GUARDS.

⚠ WARNING: A workpiece that is clamped, balanced and secure before a cut may become unbalanced after a cut is completed. An unbalanced load may tip the saw or anything the saw is attached to, such as a table or workbench. When making a cut that may become unbalanced, properly support the workpiece and ensure the saw is firmly bolted to a stable surface.

⚠ WARNING: The clamp foot must remain clamped above the base of the saw whenever the clamp is used. Always clamp the workpiece to the base of the saw—not to any other part of the work area. Ensure the clamp foot is not clamped on the edge of the base of the saw.

SUPPORT FOR LONG PIECES (FIG. 1)

⚠ WARNING: To reduce the risk of serious personal injury, turn off the tool and disconnect it from the power source before attempting to move it, change accessories or make any adjustments.

ALWAYS SUPPORT LONG PIECES.

Never use another person as a substitute for a table extension; as additional support for a workpiece that is longer or wider than the basic miter saw table or to help feed, support or pull the workpiece.

For best results, use the DW7080 extension work support to extend the table width of your saw. These are available from your dealer at extra cost.

Support long workpieces using any convenient means such as sawhorses or similar devices to keep the ends from dropping.

CUTTING PICTURE FRAMES, SHADOW BOXES AND OTHER FOUR-SIDED PROJECTS

To best understand how to make the items listed here, we suggest that you try a few simple projects using scrap wood until you develop a "FEEL" for your saw.

Your saw is the perfect tool for mitering corners like the one shown in Figure 13. Sketch A in Figure 12 shows a joint made by using the bevel adjustment to bevel the edges of the two boards at 45° each to produce a 90° corner. For this joint the miter arm was locked in the zero position and the bevel adjustment was locked at 45°. The wood was positioned with the broad flat side against the table and the narrow edge against the fence. The cut could also be made by mitering right and left with the broad surface against the fence.

FIG. 12

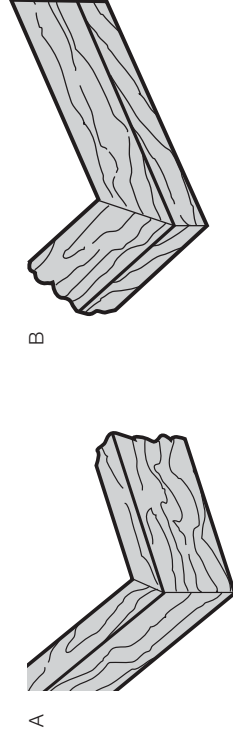

FIG. 13

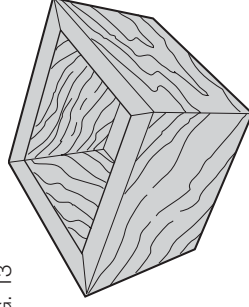
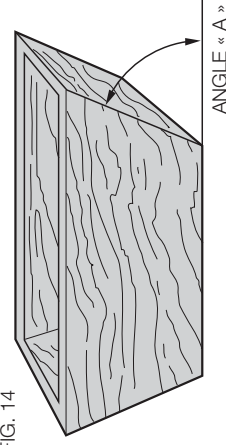

FIG. 14



CUTTING TRIM MOLDING AND OTHER FRAMES

Sketch B in Figure 12 shows a joint made by setting the miter arm at 45° to miter the two boards to form a 90° corner. To make this type of joint, set the bevel adjustment to zero and the miter arm to 45°. Once again, position the wood with the broad flat side on the table and the narrow edge against the fence.

The two sketches in Figure 12 are for four side objects only.

As the number of sides changes, so do the miter and bevel angles. The chart below gives the proper angles for a variety of shapes.

- EXAMPLES -	
NO. SIDES	ANGLE MITER OR BEVEL
4	45°
5	36°
6	30°
7	25.7°
8	22.5°
10	18°

(The chart assumes that all sides are of equal length.) For a shape that is not shown in the chart, use the following formula. 180° divided by the number of sides equals the miter (if the material is cut vertically) or bevel angle (if the material is cut laying flat).

CUTTING COMPOUND MITERS

A compound miter is a cut made using a miter angle and a bevel angle at the same time. This is the type of cut used to make frames or boxes with slanting sides like the one shown in Figure 14.

NOTE: If the cutting angle varies from cut to cut, check that the bevel clamp knob and the miter lock lever are securely tightened. These knobs must be tightened after making any changes in bevel or miter.

The chart (Table 1) will assist you in selecting the proper bevel and miter settings for common compound miter cuts. To use the chart, select the desired angle "A" (Figure 14) of your project and locate that angle on the appropriate arc in the chart. From that point follow the chart straight down to find the correct bevel angle and straight across to find the correct miter angle. Set your saw to the prescribed angles and make a few trial cuts. Practice fitting the cut pieces together until you develop a feel for this procedure and feel comfortable with it.

Example: To make a four-sided box with 26° exterior angles (Angle A, Figure 14), use the upper right arc. Find 26° on the arc scale. Follow the horizontal intersecting line to either side to get miter angle setting on saw (42°). Likewise, follow the vertical intersecting line to the top or bottom to get the bevel angle setting on the saw (18°). Always try cuts on a few scrap pieces of wood to verify settings on saw.

VERNIER SCALE (FIG. 15, 16)

Your saw is equipped with a vernier scale for added precision. The vernier scale allows you to accurately set miter angles to the nearest 1/4°. To use the vernier scale follow the steps listed below.

- (As an example, let's assume that the angle you want to miter is 25-1/4° left).
- 1. Turn off miter saw.
- 2. Set the miter angle to the nearest whole degree desired by aligning the center mark in the vernier scale, shown in Figure 15, with the whole degree number etched in the miter scale. Examine Figure 15 closely; the setting shown is 25° left miter.
- 3. To set the additional 1/4°, squeeze the miter arm lock and carefully move the arm to the LEFT until the 1/4° vernier mark aligns with the CLOSEST degree mark on the miter scale (Fig. 16). In our example, the closest degree mark on the miter scale happens to be 26°. Figure 16 shows a setting of 25-1/4° right miter.

FIG. 15

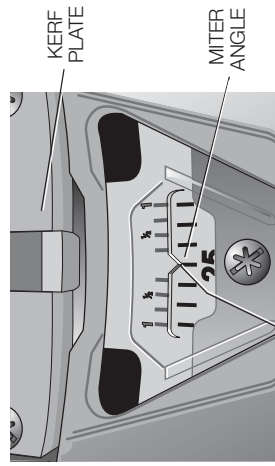

CENTER MARK ON VERNIER SCALE ALIGNS WITH DESIRED WHOLE ANGLE ON MITER SCALE (25° LEFT MITER)

FIG. 16

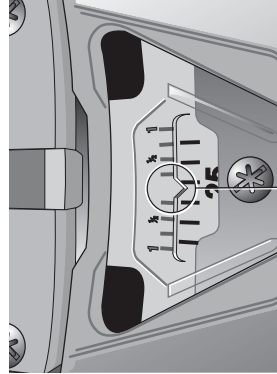

1/4° VERNIER MARK ALIGNS WITH CLOSEST WHOLE DEGREE MARK ON MITER SCALE (25-1/4° LEFT MITER)

For settings that require partial degrees (1/4, 1/2, 3/4°) align the desired vernier mark with the CLOSEST degree mark on the miter scale, as described below (The plastic vernier plate is inscribed with marks for 1/4, 1/2, 3/4 and 1°. Only the 1/2° and the 1° are numerically labeled.)

WHEN MITERING TO THE RIGHT

To increase the miter angle when mitering to the right, move the arm to align the appropriate vernier mark with the closest mark on the miter scale to the right. To decrease the miter angle when mitering to the right, move the arm to align the appropriate vernier mark with the closest mark on the miter scale to the left.

WHEN MITERING TO THE LEFT

To increase the miter angle when mitering to the left, move the arm to align the appropriate vernier mark with the closest mark on the miter scale to the left. To decrease the miter angle when mitering to the left, move the arm to align the appropriate vernier mark with the closest mark on the miter scale to the right.

FIG. 17

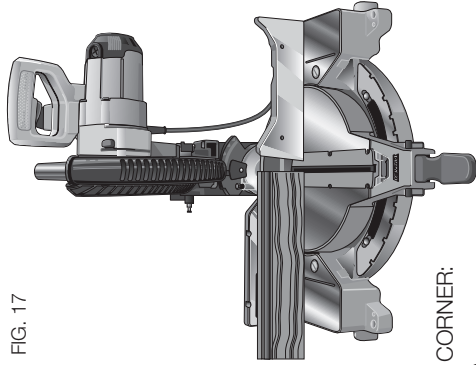

CUTTING BASE MOLDING
ALWAYS MAKE A DRY RUN WITHOUT POWER BEFORE MAKING ANY CUTS.
Straight 90° cuts:

Position the wood against the fence and hold it in place as shown in Figure 17. Turn on the saw, allow the blade to reach full speed and lower the arm smoothly through the cut.

CUTTING BASE MOLDING UP TO 1" (25.4 mm) THICK BY UP TO 3-5/8" (91 mm) WIDE VERTICALLY AGAINST THE FENCE

- Position molding as shown in Figure 17
- All cuts made with the back of the molding against the fence and bottom of the molding against the base.

INSIDE CORNER:

- Left side
 - 1. Miter left 45°
 - 2. Save left side of cut
- Right side
 - 1. Miter Right 45°
 - 2. Save right side of cut

OUTSIDE CORNER:

- Left side
 - 1. Miter right at 45°
 - 2. Save left side of cut
- Right side
 - 1. Miter left at 45°
 - 2. Save right side of cut

FIG. 18

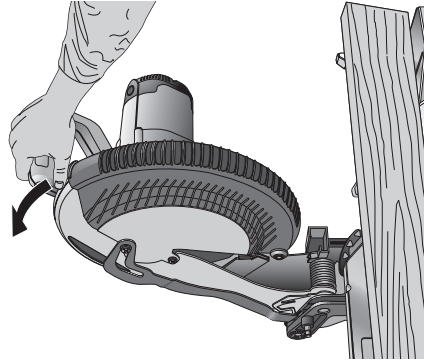

Material up to 3-5/8" (91 mm) can be cut as described above. For boards [up to 6-3/4" (173 mm)] several minor concessions must be made:

When cutting a board between 3-5/8" (91 mm) and 6-3/4" (173 mm), the roller on the tip of the guard will hang up on the workpiece. If this occurs, simply place your right thumb on the upper side of the guard and roll the guard up just enough to clear the workpiece, as shown in Figure 18. Once you have cleared the workpiece, you can release the guard and it will continue to open as the cut progresses. When mitering to the right side of a base molding 3-5/8" (91 mm) standing vertically against the fence as in Figure 17, the saw can only cut through the board up to 1" (25.4 mm) from the end of the board. Trying to cut more than an inch will cause the saw's gear case to interfere with the workpiece. If you want to cut base molding between 3-5/8" (91 mm) and 6-3/4" (173 mm) vertically follow the directions on this page.

CUTTING BASE MOLDING UP TO 1" (25.4 mm) THICK BY 3-5/8" – 6-3/4" (91 X 173 mm) WIDE 1" (25.4 mm) VERTICALLY AGAINST THE FENCE

- Position molding as shown in Figure 17
- All cuts made with the back of the molding against the fence

INSIDE CORNER:

Left side

1. Position molding with bottom of molding against the base of the saw
2. Miter left 45°
3. Save left side of cut

Right side

1. Position molding with top of the molding resting on the base of the saw
2. Miter left 45°
3. Save the right side of cut

*** NOTE:** If the cut must be made somewhere other than 1" from the end of the molding: cut off the molding at 90° approx. 1" (25.4 mm) longer than your final length then make the miter cut as described above.

CUTTING BASE MOLDING UP TO 1.8" (45 mm) THICK BY UP TO 7-11/16" (195.6 mm) WIDE LAYING FLAT AND USING THE BEVEL FEATURE

- All cuts made with the saw set at 45° bevel and 0 miter.
- All cuts made with back of molding laying flat on the saw as shown in Figure 19.

FIG. 19

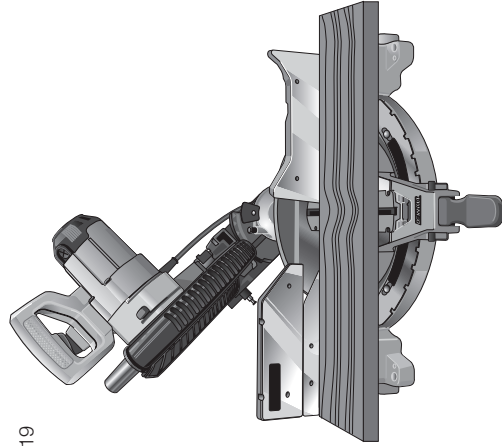

INSIDE CORNER:

Left side

1. Position molding with top of molding against the fence
2. Save left side of cut

Right side

1. Position molding with bottom of the molding against the fence
2. Save right side of cut

INSIDE CORNER:

Right side

1. Position molding with bottom of the molding against the fence
2. Save left side of cut

OUTSIDE CORNER:

Right side

1. Position molding with top of molding against the fence
2. Save right side of cut

CUTTING CROWN MOLDING

Your miter saw is better suited to the task of cutting crown molding than any tool made. In order to fit properly, crown molding must be compound mitered with extreme accuracy. The two flat surfaces on a given piece of crown molding are at angles that, when added together, equal exactly 90°. Most, but not all, crown molding has a top rear angle (the section that fits flat against the ceiling) of 52° and a bottom rear angle (the part that fits flat against the wall) of 38°.

Your miter saw has special pre-set miter latch points at 31.62° left for cutting crown molding at the proper angle and bevel stop pawl at 33.85° left. There is also a mark on the bevel scale at 33.85°.

The **Bevel Setting/Type of Cut** chart gives the proper settings for cutting crown molding. (The numbers for the miter and bevel settings are very precise and are not easy to accurately set on your saw.) Since most rooms do not have angles of precisely 90°, you will have to fine tune your settings anyway.

PRETESTING WITH SCRAP MATERIAL IS EXTREMELY IMPORTANT! INSTRUCTIONS FOR CUTTING CROWN MOLDING LAYING FLAT AND USING THE COMPOUND FEATURES

1. Molding laying with broad back surface down flat on saw table (Fig. 20).

FIG. 20

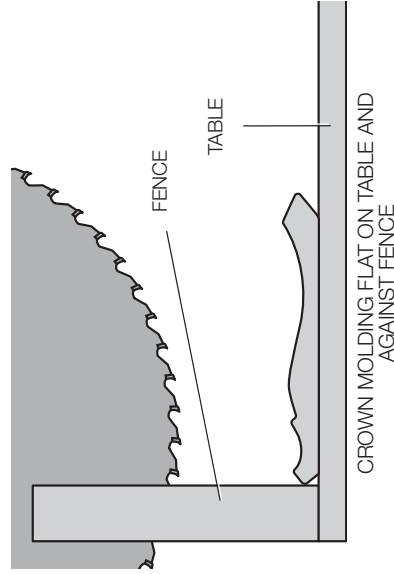

2. The settings below are for All Standard (U.S.) crown molding with 52° and 38° angles.

BEVEL SETTING	TYPE OF CUT
33.85°	LEFT SIDE, INSIDE CORNER:
	1. Top of molding against fence
	2. Miter table set right 31.62°
33.85°	RIGHT SIDE, INSIDE CORNER:
	1. Bottom of molding against fence
	2. Miter table set left 31.62°

2. The angled "flats" on the back of the molding must rest squarely on the fence and base of the saw.

INSIDE CORNER:

Left side

1. Miter right at 45°
2. Save right side of cut

INSIDE CORNER:

Right side

1. Miter left at 45°
2. Save left side of cut

OUTSIDE CORNER:

Left side

1. Miter left at 45°
2. Save right side of cut

OUTSIDE CORNER:

Right side

1. Miter right at 45°
2. Save left side of cut

Special Cuts

NEVER MAKE ANY CUT UNLESS THE MATERIAL IS SECURED ON THE TABLE AND AGAINST THE FENCE.

ALUMINUM CUTTING

ALWAYS USE THE APPROPRIATE SAW BLADE MADE ESPECIALLY FOR CUTTING ALUMINUM. These are available at your local DEWALT retailer or DEWALT service center. Certain workpieces, due to their size, shape or surface finish, may require the use of a clamp or fixture to prevent movement during the cut. Position the material so that you will be cutting the thinnest cross section, as shown in Figure 21. Figure 21A illustrates the wrong way to cut these extrusions. Use a stick wax cutting lubricant when cutting aluminum. Apply the stick wax directly to the saw blade before cutting. Never apply stick wax to a moving blade.

The wax, available at most hardware stores and industrial mill supply houses, provides proper lubrication and keeps chips from adhering to the blade. Be sure to properly secure workpiece.

FIG. 21

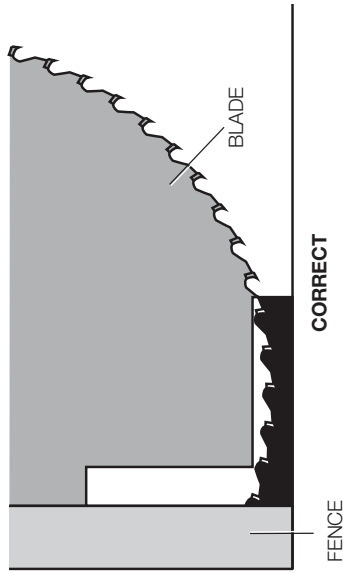

BEVEL SETTING

TYPE OF CUT

LEFT SIDE, OUTSIDE CORNER:

1. Bottom of molding against fence
2. Miter table set left 31.62°
3. Save right end of cut

RIGHT SIDE, OUTSIDE CORNER:

1. Top of molding against fence
2. Miter table set right 31.62°
3. Save right end of cut

When setting bevel and miter angles for all compound miters, remember that:

The angles presented for crown moldings are very precise and difficult to set exactly. Since they can easily shift slightly and very few rooms have exactly square corners, all settings should be tested on scrap molding.

PRETESTING WITH SCRAP MATERIAL IS EXTREMELY IMPORTANT!

ALTERNATIVE METHOD FOR CUTTING CROWN MOLDING

Place the molding on the table at an angle between the fence and the saw table, as shown in Figure 20A. Use of the crown molding fence accessory (DW7084) is highly recommended because of its degree of accuracy and convenience. The crown molding fence accessory is available for purchase from your local dealer.

The advantage to cutting crown molding using this method is that no bevel cut is required. Minute changes in the miter angle can be made without affecting the bevel angle. This way, when corners other than 90° are encountered, the saw can be quickly and easily adjusted for them. Use the crown molding fence accessory to maintain the angle at which the molding will be on the wall.

FIG. 20A

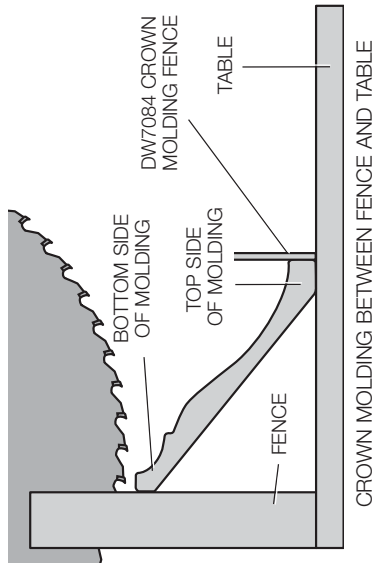

INSTRUCTIONS FOR CUTTING CROWN MOLDING ANGLED BETWEEN THE FENCE AND BASE OF THE SAW FOR ALL CUTS:

1. Angle the molding so the bottom of the molding (part which goes against the wall when installed) is against the fence and the top of the molding is resting on the base of the saw, as shown in Figure 20A.

FIG. 21A

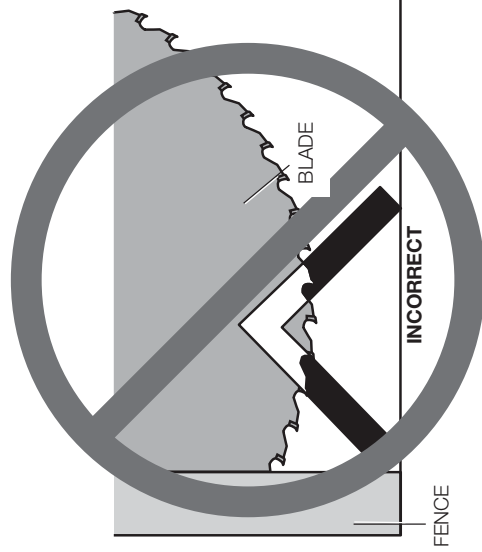

Refer to **Saw Blades** under **Accessories** for correct saw blade.

BOWED MATERIAL

When cutting bowed material always position it as shown in Figure 22 and never like that shown in 22A. Positioning the material incorrectly will cause it to pinch the blade near the completion of the cut.

FIG. 22

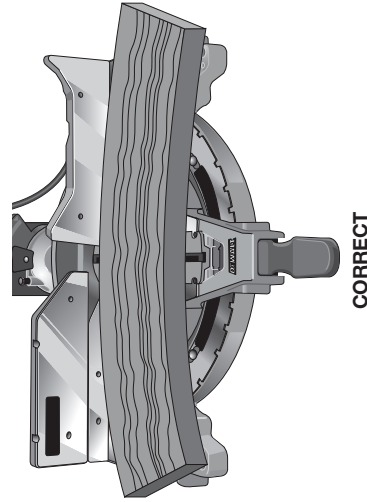
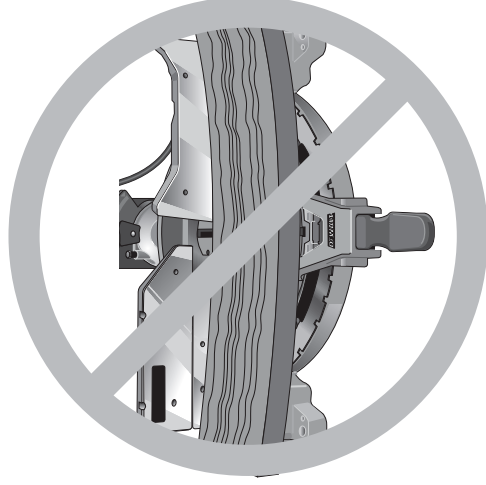

FIG. 22A



INCORRECT

CUTTING PLASTIC PIPE OR OTHER ROUND MATERIAL

Plastic pipe can be easily cut with your saw. It should be cut just like wood and **CLAMPED OR HELD FIRMLY TO THE FENCE TO KEEP IT FROM ROLLING**. This is extremely important when making angle cuts.

CUTTING LARGE MATERIAL

Occasionally you will encounter a piece of wood a little too large to fit beneath the blade guard. If this occurs, simply place your right thumb on the upper side of the lower blade guard and roll the guard up just enough to clear the workpiece, as shown in Figure 18. Release the lower blade guard before turning the saw on and beginning the cut. Avoid doing this as much as possible, but if need be, the saw will operate properly and make the bigger cut. **NEVER TIE, TAPE, OR OTHERWISE HOLD THE GUARD OPEN WHEN OPERATING THIS SAW.**

MAINTENANCE

DO NOT use lubricants or cleaners (particularly spray or aerosol) in the vicinity of the plastic guard. The polycarbonate material used in the guard is subject to attack by certain chemicals.

1. All bearings are sealed. They are lubricated for life and need no further maintenance.
2. Periodically clean all dust and wood chips from around AND UNDER the base and the rotary table. Even though slots are provided to allow debris to pass through, some dust will accumulate.
3. The brushes are designed to give you several years of use. To replace the brushes refer to **Brushes** or return the tool to the nearest service center for repair.

Service Information

Please have the following information available for all service calls:

Model Number _____ Type _____ Serial Number _____
 Date and Place of Purchase _____

Repairs

To assure product **SAFETY** and **RELIABILITY**, repairs, maintenance and adjustment should be performed by a DEWALT factory service center, a DEWALT authorized service center or other qualified service personnel. Always use identical replacement parts.