

Vibratory Bowl - 18 LB. Capacity

Item 96923

WARNING

Read this material before using this product.
Failure to do so can result in serious injury.
SAVE THIS MANUAL.



When unpacking, make sure that the product is intact and undamaged.
If any parts are missing or broken, please call 1-800-444-3353 as soon as possible.

Visit our website at: <http://www.harborfreight.com>

Specifications

Electrical Requirements	120 V~ / 60 Hz
Maximum Capacity	18 lb.

Save This Manual

Keep this manual for the safety warnings and precautions, assembly, operating, inspection, maintenance and cleaning procedures. Write the product's serial number in the back of the manual near the assembly diagram (or month and year of purchase if product has no number). Keep this manual and the receipt in a safe and dry place for future reference.

Important Safety Information

In this manual, on the labeling, and all other information provided with this product:



This is the safety alert symbol. It is used to alert you to potential personal injury hazards. Obey all safety messages that follow this symbol to avoid possible injury or death.

DANGER

DANGER indicates a hazardous situation which, if not avoided, will result in death or serious injury.

WARNING

WARNING indicates a hazardous situation which, if not avoided, could result in death or serious injury.

CAUTION

CAUTION, used with the safety alert symbol, indicates a hazardous situation which, if not avoided, could result in minor or moderate injury.

NOTICE

NOTICE is used to address practices not related to personal injury.

CAUTION

CAUTION, without the safety alert symbol, is used to address practices not related to personal injury.

When using electrical appliances, safety precautions should always be followed including the following:

Work Area Safety

1. Do not use outdoors.
2. Close supervision is necessary when any appliance is used by or near children.
3. Do not let cord hang over edge of table or counter, or touch hot surfaces.
4. Extreme caution must be used when moving an appliance.
5. Keep the work area well lit. Make sure there is adequate surrounding workspace. Keep the work area free of obstructions and other debris.

Electrical Safety

6. Only use a GFCI protected power source when using wet media in the unit.
1. Unplug from outlet when not in use and before maintenance or cleaning.
2. Do not operate any appliance with a damaged cord or plug or after the appliance malfunctions or has been damaged in any manner. Return appliance to the nearest authorized service facility for examination, repair, or adjustment.
3. This appliance has a polarized plug (one blade is wider than the other). To reduce the risk of electric shock, this plug is intended to fit into a polarized outlet only one way. If the plug does not fit fully in the outlet, reverse the plug. If it still does not fit, contact a qualified electrician. Do not change the plug in any way.
4. Do not use this product in a damp or wet location.

Power Cord Safety

1. A short power supply cord is to be provided to reduce risks resulting from becoming entangled in or tripping over a longer cord.
2. Longer extension cords are available and may be used if care is exercised in their use.
3. If a long extension cord is used,
 - a. The marked electrical rating of the (detachable power supply cord or) extension cord should be at least as great as the electrical rating of the appliance,
 - b. If the appliance is of the grounded type, the extension cord should be a grounding type 3-wire cord, and
 - c. The longer cord should be arranged so that it will not drape over the counter

top or tabletop where it can be pulled on by children or tripped over.

to the State of California to cause cancer, and birth defects or other reproductive harm. Wash hands after handling. (California Health & Safety Code § 25249.5, *et seq.*)

General Safety

1. The use of accessory attachments not recommended by the appliance manufacturer may cause injuries.
2. Attach plug to appliance first, then plug cord into the wall outlet. To disconnect, turn any control to "off", then remove plug from wall outlet.
3. Do not use appliance for other than intended use.
4. Maintain labels and nameplates on the appliance. These carry important safety information. If unreadable or missing, contact Harbor Freight Tools for a replacement.
5. This product is not a toy. Keep it out of reach of children when children are not being closely supervised.
6. Inspect before use; do not use if insulation is damaged or parts are loose.
7. Keep out of reach of children.
8. Keep hands out from under bowl when plugged in.
9. Wear ANSI-approved safety goggles and dust mask or respirator during set up and use.
10. Use for intended purposes only.
11. Use on flat, level surface away from edge.
12. People with pacemakers should consult their physician(s) before use. Electromagnetic fields in close proximity to heart pacemaker could cause pacemaker interference or pacemaker failure.
13. **WARNING:** Some dust created by power sanding, sawing, grinding, drilling, and other construction activities, contains chemicals known [to the State of California] to cause cancer, birth defects or other reproductive harm. Some examples of these chemicals are:
 - Lead from lead-based paints
 - Crystalline silica from bricks and cement or other masonry products
 - Arsenic and chromium from chemically treated lumberYour risk from these exposures varies, depending on how often you do this type of work. To reduce your exposure to these chemicals: work in a well ventilated area, and work with approved safety equipment, such as those dust masks that are specially designed to filter out microscopic particles. (California Health & Safety Code § 25249.5, *et seq.*)
14. **WARNING:** Handling the cord on this product will expose you to lead, a chemical known
15. The warnings, precautions, and instructions discussed in this instruction manual cannot cover all possible conditions and situations that may occur. It must be understood by the operator that common sense and caution are factors which cannot be built into this product, but must be supplied by the operator.



SAVE THESE INSTRUCTIONS.

Assembly



Read the **ENTIRE IMPORTANT SAFEGUARDS** section at the beginning of this manual including all text under subheadings therein before set up or use of this product.

WARNING

Before appliance assembly or adjustment, make sure the appliance's switch is turned off, the cord is unplugged, and the unit has cooled completely.

Note: For additional information regarding the parts listed in the following pages, refer to the Assembly Diagram near the end of this manual.

1. Clean the appliance before use as explained in the Maintenance section.
2. Ensure that the Drain Plugs (39) are secure and will not leak if fluid is added to the Tumbler Bowl (6).
3. Do not plug in the Vibratory Bowl until ready for operation.

Preparation

1. This Vibratory Bowl is designed for deburring, cleaning or polishing work materials of various types using either wet or dry polishing media.

Note: Very sharp or hard work materials or media may cause excessive wear on the Vibratory Bowl (6). Do not use very sharp or hard materials in this appliance.

2. Various media are available for different jobs. Select the appropriate media and running time for your work material. The chart below offers suggestions for various situations. Always do a test run on a few pieces of work material to test the media and running time before committing work material to a specific process.

Basic Guidelines for Media Selection

For degreasing, use ground corncob, walnut shell or plastic media. Vibrate for 30 minutes to 1 hour.

To remove rust, use commercially available treated plastic media. Depending on the condition of the materials, you will have to vibrate for 2 - 6 hours.

To de-burr or polish, vibrate in walnut hull or corncob media. You may add a small amount of commercial metal polish.

This is a chart of recommended media for this Vibratory Bowl. Plastic beads are usually used with a powdered abrasive added. Walnut shells and corn cob may be used alone, or with added abrasive. Polishing materials include Rouge, Ruby Powder and Linde A.

Media Type	Abrasive	Application	Weight
Plastic Beads	Fine Silicate	Light surface reduction, surface preparation for polishing	62 lb. per cubic foot
Plastic Beads	Medium Silicate	Medium surface reduction, deburring	56 lb. per cubic foot
Plastic Beads	Coarse Aluminum Oxide	Heavy surface reduction, deburring	62 lb. per cubic foot
Walnut Shell	Rouge	Polishing, Oxide removal	45 lb. per cubic foot
Walnut Shell	None Added	Polishing	45 lb. per cubic foot
Corn Cob	None Added	Polishing	29 lb. per cubic foot
Red Rouge	1st Step Polisher	Powdered Polishing Additive	May Vary, Not Specified
Ruby Powder	Medium Polisher	Powdered Polishing Additive	May Vary, Not Specified
Linde A	Finish Polisher	Powdered Finishing Additive	May Vary, Not Specified

Additional Notes on Vibratory Media

The media used in standard rotating tumblers is generally not suitable for vibratory machines. Vibratory polishers often use dry media that is too light to be effective in standard rotating tumblers. Appropriate media for this vibratory polisher is available from Harbor Freight Tools.

Steel and ceramic media, generally used in tumbling, may also be used in heavy duty vibratory machines. However, this Vibratory Bowl is not designed to work with these heavy duty media, which will wear out the bowl prematurely.

There is a wide variety of media to be used in vibratory finishing, you are encouraged to experiment. Many shops are getting good results with unusual media such as erasers, wood pegs, bone and others.

Operation



Read the **ENTIRE IMPORTANT SAFEGUARDS** section at the beginning of this manual including all text under subheadings therein before set up or use of this product.

CAUTION: Vibratory finishing often creates dust which may be harmful to your health. Wait for at least 1 hour after vibrating is complete and the vibrator has been turned OFF before opening the vibrator. This will allow the dust to settle.

CAUTION: Never vibrate with the top off, as hazardous dust may be created, and the media or work materials may be ejected from the vibrator.

1. Fill the Vibratory Bowl (6) about 2/3 full with polishing media (not included).
2. Add work material parts to Vibratory Bowl. Do not overfill Vibratory Bowl, and do not exceed work weight limit of 18 lb. including media.
3. Place the Vibratory Lid (4) on the Vibratory Bowl (6). Place the Flat Rubber Washer (3) and the Flat Metal Washer (2) on the Center Shaft (38) as shown in the Assembly Diagram.
4. Place the Clamping Nut (1) on the Center Shaft and tighten in place. Tighten enough to keep the Vibratory Lid (4) in place. Do not overtighten.
5. Plug in the unit and press the Power Switch (29) to the ON position. The Vibratory Bowl will begin to operate.
6. When the job is completed, turn the Power Switch (29) OFF and unplug the unit.
7. Remove the Clamping Nut (1), and pull the Vibratory Lid (4) off the Center Shaft (38) bringing the Flat Metal Washer (2) and Flat Rubber Washer (3) with it. Set the Lid assembly aside.
8. If a lubricant is used, then the Overflow Hose (41) must be used to drain any excess lubricant/water into a suitable container, preventing overflow.
9. Check the work material to determine if the job is completed to satisfaction. If additional work is required, replace the Lid assembly and repeat the process. If the work is completed, unload the work material and media.
10. Store the work material as required, and dispose of the media. Do not reuse media.
11. To prevent accidents, turn off the appliance and disconnect its power supply after use. Clean, then store the appliance indoors out of children's reach.

Maintenance



WARNING Before inspection or maintenance, make sure the appliance's switch is turned off, the cord is unplugged, and the unit has cooled completely.

Do not use damaged appliances. If abnormal noise or vibration occurs, have the problem corrected before further use.

1. **BEFORE EACH USE**, inspect the general condition of the appliance. Check for loose screws, misalignment or binding of moving parts, cracked or broken parts, damaged electrical wiring, and any other condition that may affect its safe operation.

2. Do not immerse motor, cord, or plug in water or any other liquid.
3. After each use, dry with a soft cloth. Wipe the motor housing with a soft clean cloth or sponge. Allow unit to dry completely before assembly or use.

Problem	Possible Causes	Probable Solutions
Appliance will not start	1. No power at outlet. 2. Cord not connected.	1. Check power at outlet. 2. Check that cord is plugged in.
Tool will not vibrate or operates slowly	1. Vibratory Bowl is overloaded.	1. Reduce amount of material in Vibratory Bowl.
Work material is not finished properly	1. Improper media is being used. 2. Material has not been processed long enough.	1. Review media selection and try another option. 2. Unload excess material or extend vibration time cycle.

PLEASE READ THE FOLLOWING CAREFULLY

THE MANUFACTURER AND/OR DISTRIBUTOR HAS PROVIDED THE PARTS LIST AND ASSEMBLY DIAGRAM IN THIS MANUAL AS A REFERENCE TOOL ONLY. NEITHER THE MANUFACTURER OR DISTRIBUTOR MAKES ANY REPRESENTATION OR WARRANTY OF ANY KIND TO THE BUYER THAT HE OR SHE IS QUALIFIED TO MAKE ANY REPAIRS TO THE PRODUCT, OR THAT HE OR SHE IS QUALIFIED TO REPLACE ANY PARTS OF THE PRODUCT. IN FACT, THE MANUFACTURER AND/OR DISTRIBUTOR EXPRESSLY STATES THAT ALL REPAIRS AND PARTS REPLACEMENTS SHOULD BE UNDERTAKEN BY CERTIFIED AND LICENSED TECHNICIANS, AND NOT BY THE BUYER. THE BUYER ASSUMES ALL RISK AND LIABILITY ARISING OUT OF HIS OR HER REPAIRS TO THE ORIGINAL PRODUCT OR REPLACEMENT PARTS THERETO, OR ARISING OUT OF HIS OR HER INSTALLATION OF REPLACEMENT PARTS THERETO.

Parts List

Part	Description	Qty
1	Clamping Nut	2
2	Flat Metal Washer	2
3	Flat Rubber Washer	2
4	Vibratory Lid	1
5	Spring Washer Ø10	1
6	Vibratory Bowl	1
7	Phillips Head Bolt M6 x 35	5
8	Rubber Mount	9
9	Protection Cover	1
10	Hex Bolt M8 x 20	4
11	Mounting Base	1
12	Flat Washer Ø8	4
13	Lock Nut M8	4
14	Inner Hex Bolt M6 x 20	4
15	Motor Bracket	1
16	Flat Washer M6	26
17	Lock Nut M6	8
18	Rubber Mount	10
19	Spring	5
20	Bolt M6 x 25	5
21	Power Cord	1
22	Cord Stopper	1
23	Base Cover	1

Part	Description	Qty
24	Base	1
25	Bolt M6 x 25	4
26	Block	4
27	Brace	4
28	Cap Nut	4
29	Power Switch	1
30	Capacitor	1
31a	Inner Hex Bolt M5x12	2
32	Eccentric Block	2
33	Bolt M5 x 10	1
34	Flat Washer Ø5	1
35	Motor	1
36	Lock Nut M10	2
37	Flat Washer Ø10	2
38	Center Shaft M10 x 270	1
39	Plastic Drain Plug	2
40	Plastic Adapter	1
41	Overflow Hose	1
42	Plastic Clamp	1
43	Phillip Head Bolt M4 x 12	1
44	Spring Washer 4	1
45a	Nut M4	1

Assembly Diagram

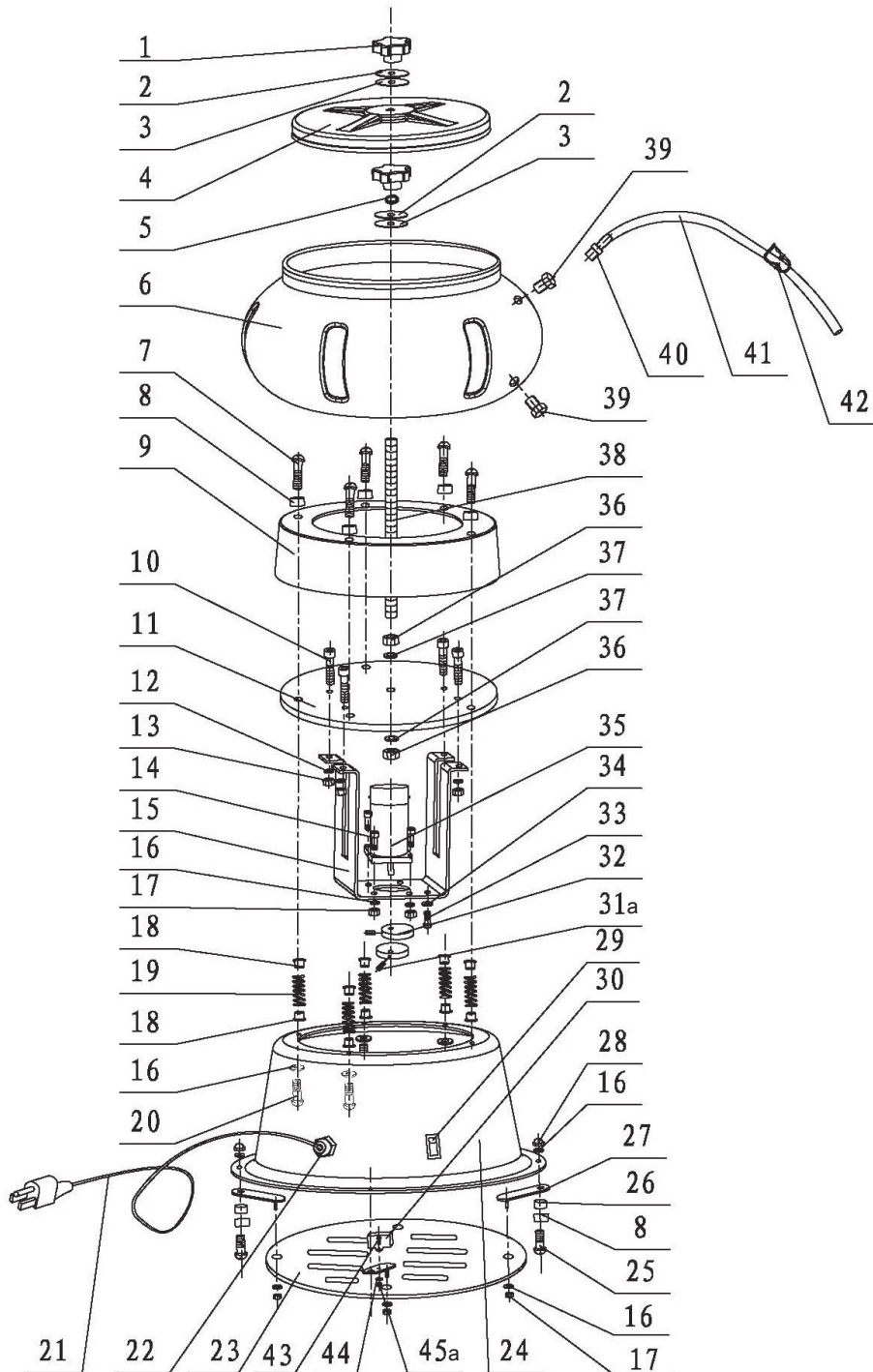

Record Product's Serial Number Here: _____

Note: If product has no serial number, record month and year of purchase instead.

Note: Some parts are listed and shown for illustration purposes only, and are not available individually as replacement parts.

Limited 90 Day Warranty

Harbor Freight Tools Co. makes every effort to assure that its products meet high quality and durability standards, and warrants to the original purchaser that this product is free from defects in materials and workmanship for the period of 90 days from the date of purchase. This warranty does not apply to damage due directly or indirectly, to misuse, abuse, negligence or accidents, repairs or alterations outside our facilities, criminal activity, improper installation, normal wear and tear, or to lack of maintenance. We shall in no event be liable for death, injuries to persons or property, or for incidental, contingent, special or consequential damages arising from the use of our product. Some states do not allow the exclusion or limitation of incidental or consequential damages, so the above limitation of exclusion may not apply to you. THIS WARRANTY IS EXPRESSLY IN LIEU OF ALL OTHER WARRANTIES, EXPRESS OR IMPLIED, INCLUDING THE WARRANTIES OF MERCHANTABILITY AND FITNESS.

To take advantage of this warranty, the product or part must be returned to us with transportation charges prepaid. Proof of purchase date and an explanation of the complaint must accompany the merchandise. If our inspection verifies the defect, we will either repair or replace the product at our election or we may elect to refund the purchase price if we cannot readily and quickly provide you with a replacement. We will return repaired products at our expense, but if we determine there is no defect, or that the defect resulted from causes not within the scope of our warranty, then you must bear the cost of returning the product.

This warranty gives you specific legal rights and you may also have other rights which vary from state to state.

CHICAGO  ELECTRIC®
POWER TOOLS

3491 Mission Oaks Blvd. • PO Box 6009 • Camarillo, CA 93011 • (800) 444-3353